

Data (Audio, Video, and Image) Transmission through Visible Light Communication: Li-Fi Technology

Muhammad Imran^{1*}, Yulong Bai¹, Mazhar Javid²

¹ College of Physics and Electronics Engineering, Northwest Normal University, China

² Department of Software Engineering, Taiyuan University of Technology, China



Accepted May 27, 2021

Published May 30, 2021

*Corresponding Author:

Muhammad Imran

DOI: <https://doi.org/10.5281/zenodo.4863444>

Pages: 245-256

Funding: None

Distributed under
Creative Commons CC BY 4.0

Copyright: © The Author(s)

How to cite this article (APA):

Imran, M., Bai, Y., & Javid, M. (2021). Data (Audio, Video, and Image) Transmission through Visible Light Communication: Li-Fi Technology. *North American Academic Research*, 4(5), 245-256. doi:<https://doi.org/10.5281/zenodo.4863444>

Conflicts of Interest

There are no conflicts to declare.

ABSTRACT

Li-fi stands for light fidelity and was proposed by the German physicist Harald Haas in 2011. Li-Fi refers to visible light communication that uses light emitting diodes (LED's) for high speed data transmission in the visible region of electromagnetic spectrum. LED lights is not only use for lighting purpose but can also be used as a medium for data transmission through visible light communication. Visible light communication (VLC) is the latest innovation which is used for sending of data in the visible region of electromagnetic spectrum of light. The transmission happens in the form of binary data 0's and 1's. 0 means LED is in the OFF state and 1 means LED is in the ON state. Visual Studio is used to visualize the process of sending data. Programmed Arduino is used as a microprocessor at both Transmitter and receiver sides. High power intensity LED's are used at the transmitter side for the generation of light. At the receiver section, photodiode is used to detect the light signal generated by the LED's at the transmitter side. In this paper, we shows the transmission of three different types of data. They are audio, video, text, and image file. We obtain 100% successful result of transmitted image, audio, video, and text file. Experimental results show that high quality image, audio and video with the maximum distance of 12 feet's can be achieved through proper arrangement of transmitter and receiver.

Keywords: LED'S LIGHT, PHOTODIODE, RECEIVER, TRANSMITTER, VISIBLE LIGHT COMMUNICATIONS

1. Introduction

Li-Fi was firstly introduce by Professor Harald Haas nine year ago in March 2011 which he call "data through illumination". The idea is based on data transmission through visible light. It can also be known as light-based wireless fidelity (Wi-Fi). Here, instead of Wi-Fi modems, transceiver fitted with LED's is used as a source of illumination and data transmission. (Bhut JH, et al 2014) explain the concept of Li-Fi Technology. Li-Fi can be more preferred than Wi-Fi because of some limitations in Wi-Fi. The signal reliability is dependent on the number of user's access to the networks and the volume of Wi-Fi traffic. The

reliability get reduces with the increase in number of users connect with Wi-Fi. Speed and security are also main factors. Wi-Fi is defenseless to hackers because its waves can passing through walls and opaque objects. Morse code as an on-off series that happening so fast, its invisible to the human eye. VLC technology also known as light fidelity Li-Fi and it is highly expected to be the replacement of Wi-Fi for indoor communication. It has the speed of 100 Gigabits per second to transmit data. The average speed of Wi-Fi is 10 (Mbps), that's why Li-Fi is 1 Gbps as fast as Wi-Fi. Also we can say that Wi-Fi is 100 times slower than Li-Fi. The available frequency spectrum for VLC is from 430 THz to 790 THz and the wavelength range from 380 nm to 750 nm as shown in Fig.1. To overcome the shortcomings of RF communication systems, wireless technology need to design a new communication system. VLC is the best alternative to replace RF communication. Professor Harald Haas in his TED talk, show some limitations of Wi-Fi which needs to overcome are given below.

- ❖ **Capacity:** Wi-Fi use radio wave to transmit data which are limited bandwidth spectrum as well as expensive. While visible light spectrum is 10,000 time larger than that of radio waves. Also it is inexpensive because the light sources are already installed.
- ❖ **Efficiency:** There are 1.4 million of cellular radio masts all over the world. These masts consume a very huge amounts of energy, most of which is used for cooling the station rather than transmission of radio waves. Due to which the efficiency is only 5%. While LED's light consume a very less amount of energy and is considered to be most efficient.
- ❖ **Availability:** Radio waves cannot be used in most of the environments, mainly in airplanes, chemical plants, power plants and in hospitals while light are available and can be used anywhere. Hence availability is not a big problem
- ❖ **Security:** Wi-Fi is defenseless to hackers because its waves can passing through walls and opaque objects Radio waves can penetrate through walls while Light cannot penetrate through walls, thus Li-Fi is more secure than Wi-Fi. Figure 1 shows visible region of the electromagnetic spectrum.

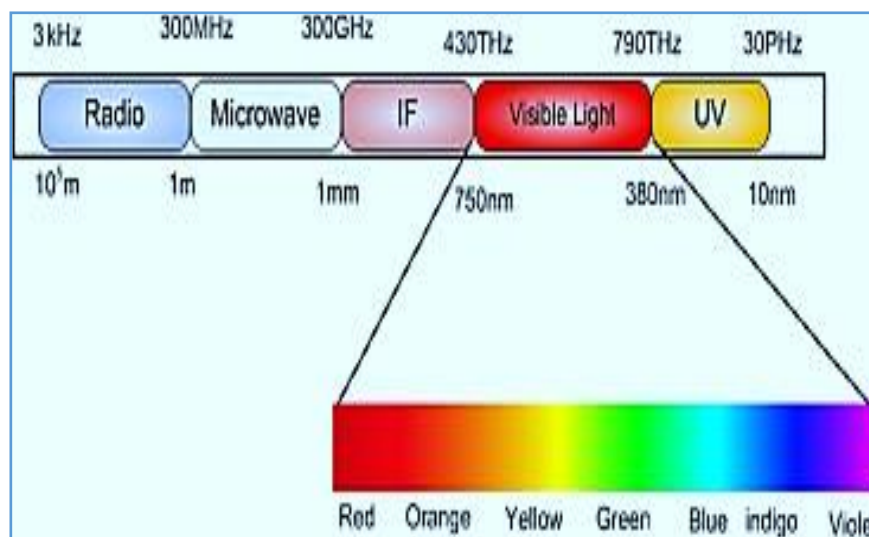

Figure 1. Visible Region of Electromagnetic spectrum

Wireless communication play a very important role in the world of data communication. In 2007, the number of smartphones sold worldwide is round about 122.32 million. The figure reaches 969.72 million in 2013. Furthermore the number reaches to 1.524 billion in 2019 and expected to extend this figure to 1.582 billion in 2021. from this it is concluded that how much wireless communication is important.

(Singh AJ & Veeraiahgari A, 2014) explain “Light-Fidelity that how visible light communication (VLC) technology is applied to high speed wireless communication”. Wireless data communication through radio waves is the most used system of communication worldwide, but because of the short frequency bandwidth, it has been get limited. For this VLC is introduced to overcome this issue. Visible light spectrum is 10,000 times larger than that of radio frequency spectrum. Also it has three additional advantages.

- **Intrinsic security:** As the light wave cannot passes through walls due to which an unlicensed person cannot access the network.
- **high-speed communication**
- **Low power consumption:** No power is lost, because the VLC system use light as a sources of data transmission.

(Karthika R & Balakrishnan, 2015) deal with the wireless communication using L-Fi Technology. They also show the comparison of Li-Fi technology with other technology. Visible light communication is one of the innovative technology among other existing transmission technologies in the world of data communication. Its high bandwidth, fast data rate and immunity to interference make it distinctive in the regions where high data transfer is needed. It has many application including audio, video, text and image transmission. In transmitting data, light emitting diodes are used at the transmitting side and photodiodes are used at the receiving side. LED light carries the data in the form of 1’s and 0’s by switching on and off the light at very high speed rates.

A recently new report by CISCO about data traffic, that there will be 11-fold increase in mobile data traffic in 2018 compared to 2013 as shown in Fig:2 The increase in the number of smartphones (device) logging in to the mobile networks is the mainly reason for high increase in mobile data traffic. Also with the development of social networks like Facebook, Twitter and Instagram made further more increased in mobile data traffic. The data traffics is shown in Figure 2.

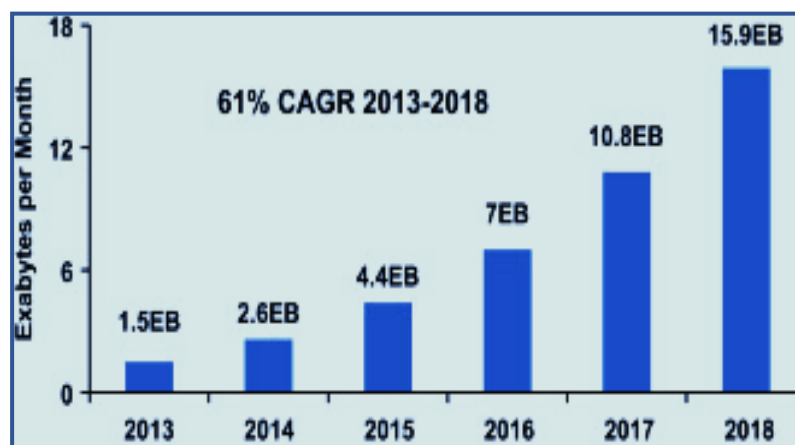

Figure 2. Report by CISCO about data traffic

A new report of GBI Research about global Wireless Spectrum Shortage show that visible light communication is the best way to solve the problem of spectrum shortage. This problem happen with ever increasing usage of data over mobile phones and other wireless devices. Solving this problem need to introduce a new way of wireless communication for which Visible light communication can be offered as a best possible solution (Mahato K, et al 2021).

Visible light communication has numerous applications in different fields including hospital, vehicle to vehicle communication, aviation, underwater communication, industrial automation, information displayed on sign boards (advertisement), home and building automation, and education. In vehicle to vehicle communication, VLC is used to avoid accident by warning the traffic signal. This kind of communication need low latency which is delivered by VLC. Visible light communication can also be used in the regions which are very sensitive to electromagnetic waves such as aircrafts and hospitals where the radio wave interfere with the waves of other machines (Asoke Nath, et al 2015).

(He Y, et al 2013) present Real-time Audio & Video Transmission System Based on Visible Light Communication. With the continues improvement and development of solid state lighting devices, Visible Light Communication (VLC) is going familiar as an innovative and promising technology to get high speed and large capacity wireless data transmission. The paper deal with real-time audio and video transmission method using cheap LED's which are easily offered in the markets. The paper also proposed a lighting model to supply illuminance. From the results it is illustrated that real-time audio and video is transmitted through visible light at a distance of 2.5 m is achieved through proper arrangement of LED's sources and improvement of concentration effects.

(Ma'ruf MI, 2015) Design and implement a system for audio transmission through Visible Light Communication System (VLC). The objectives of their paper is to design, simulate and verify the system using LED's and photo transistor. To check the system, they use audio signals to transmit & receive through visible light communication circuit. A 100% successful results has been achieved on audio signals transmission and receiving at a distance of 1.7 meter.

(Singh S, et al 2015) deal with the Visible Light Communication as an Emerging Wireless Communication Technology. The paper discussed Visible Light Communication (VLC) as an emerging technology, which offers unique facilities such as fastest data transmission, high security communication, and high frequency bandwidth etc. The visible electromagnetic spectrum is 10,000 time wider than radio frequency spectrum. The authors here shows comparative study of Wi-Fi and Li-Fi system. The paper emphasizes Visible Light Communication technologies (VLC) their applications, advantages and limitations which needs to overcome in the near future.

(Madhuri G, et al 2020) present a Li-Fi system for data (audio and text file) transmission using visible light communication. The objective of the system is study various topology of light fidelity and transmit audio and text file signal through (VLC). In the proposed system, data is transmitted in the form of stream bits. Stream of bits are the binary data of 0's and 1's. 0's means, LED is in the OFF state and 1 means, LED is in the ON state.

The system use IR detector for decoding the information and photodiode at the receiver side. Here, two different signals can be transmitted through Li-Fi system. Programmable Arduino are used at both transmitter and receiver section. (Tsaqifurrosyid A, et al 2020) deal with image transmission through visible light communication system. The goal of the paper is to develop a method that can transmit image file through visible light communication. Here, the simulation of data occurred at the transmitter and at the receiver side, visual studio is used to visualize the information. From the results it is illustrated that high quality image file is transmitted through visible light at a distance of 50cm through proper arrangement of LED's sources and receiver section. The result also shows 30 minute of delivery time. According to the paper, Arduino UNO is used as a microprocessor.

(Sharma RR, et al 2014) use Li-Fi Technology to transmit Data through Visible Light. The objectives of the paper is to introduce Li-Fi system and compare it with Wi-Fi system. The paper discuss the Li-Fi system that how it will replace the RF wave communication. The system use LED's to transmit data through light lie in the visible region of electromagnetic spectrum. The results of the paper is study the Li-Fi system in details, its future scope and its advantages in comparison with Wi-Fi system. The paper also described that how Li-Fi will replace Wi-Fi in the coming future.

We have made a new VLC system composed of transmitter section and receiver section. LED's at the transmitter side is used to generate light and photodiode at the receiver side is used to detect the light signal. Both the sections are placed at a maximum distance of 12 feet's apart from each other. Computing devise modulate the data at the transmitting side and send it to the LED driver. LED driver control the rapidly blinking of LED's. The blinking of LED is so fast that human eye cannot detect it. This blinking of LED is detected by the photodiode at the receiver side. The received signal is demodulated and getting back the original information. The bits sent contain noise which cause Bit Error Rate. To reduce this error to approximately zero, we set up demodulation.

2. Methodology

Step 1: Electrical Signal is converted into optical in order to transmit data

Step 2: The information will be converted to binary values and transmitted via light using a li-fi transmitter.

Step 3: The photo detector receives light from the transmitter side.

Step 4: The binary values are converted into optical signals once more. The optical signal is converted back into electrical signal. As a consequence, the user may examine their results on a computer.

3. Proposed system

Visible Light Communication is a free space optical communication system. Visible Light Communication (VLC) is an optical communication device that exists in free space. In the OWC system, the line of sight (LOS) is the common connection between two points. The transmitter is used to direct the visible light beam to the receiver in a clear and unobstructed direction. For data transmission, the prototype may use intensity modulation

and direct detection. Li-fi is a brand-new data transmission method. Data is sent by varying the light's intensity, which is subsequently detected by a photo detector. A light source serves as the transmitter, while a photo detector serves as the receiver in VLC technology. Electrical signals are converted into optical signals in the transmitter section and is transmitted via LED. A photo detector is included in the receiver. The optic signal is converted to an electrical signal by the photo detector. Using more than one led at a time adds sophistication to this method. Figure 3. Shows how the devices are put together.

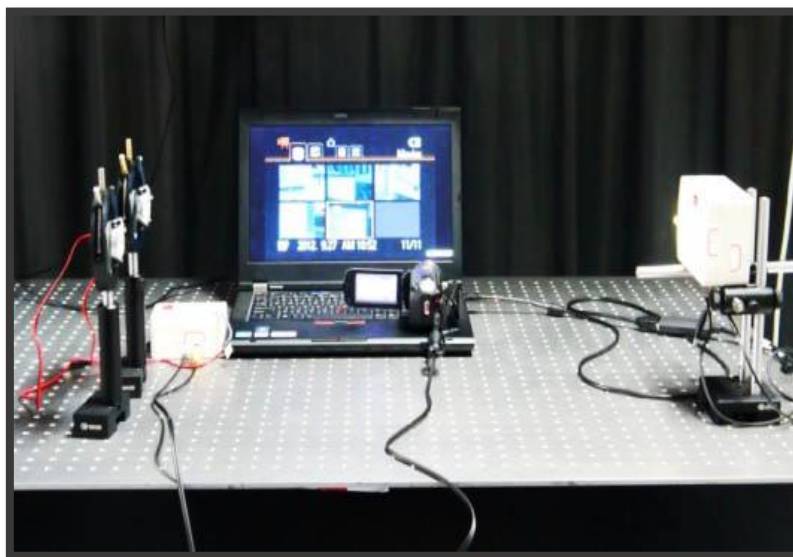

Figure 3. Picture of the video/audio transmission prototype using LEDs.

Basic sections of proposed system

- Power Supply Section
- Transmitter Section
- Receiver Section

3.1 power supply section

The transmitter and receiver sections are both powered by 5V DC. The regulating IC 7805 is used to design it. The bridge rectifier is made using 1N4007 diode. The fixed-voltage integrated-circuit voltage regulators in the 780x series are suitable for a wide range of applications. Each of these regulators has a maximum output current of 1.5 A. These regulators are resistant to overload due to their inherent current-limiting and thermal-shutdown characteristics. These devices can be used as power-pass elements in precision regulators, as well as fixed-voltage regulators. They can also be used with external components to achieve adjusted output voltages and currents. Figure 4 show the circuit diagram for power supply.

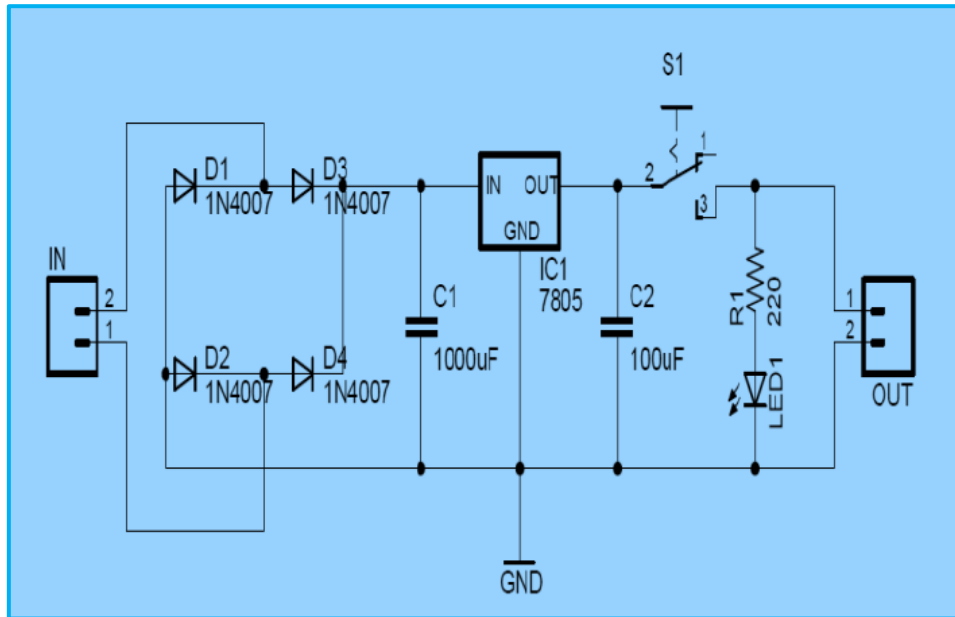

Figure 4. Circuit diagram for power supply

3.2 Transmitter

The transmitter section is where data is sent from the transmitter PC to the receiver PC. The transmitter section use a Computer with a MATLAB software installed in it and Max 232 IC. The visible light source is the most important component in the transmitter section. The data is transmitted using the serial communication technique using LED light as a source. The RS 232 pin is used to communicate between the serial port and the computer. For appropriate analysis, we transmitted audio video and image file from one computer to another. (Ahfayd MH, et al 2014) LED light source is the main component of the transmitter section. Here, a high power ‘cool’ white LED is used. The bandwidth of ‘cool’ white LEDs is greater than that of ‘warm’ white LEDs, resulting in rapid data transfer. 20 W and 30 W ‘cool’ LEDs accomplished the best performance in terms of data transmission rate and distance, as well as environmental lighting.

Before transmission, the data is change into its equivalent binary through MATLAB software. A USB to Serial port converter was chosen since current PCs and laptops feature are serial output port. A MAX 232 IC is used to convert the computer's output to a constant output. The transmission happens in the form of binary data 0’s and 1’s. 0 means LED is in the OFF state and 1 means LED is in the ON state. Figure 5 the transmitter circuit diagram.

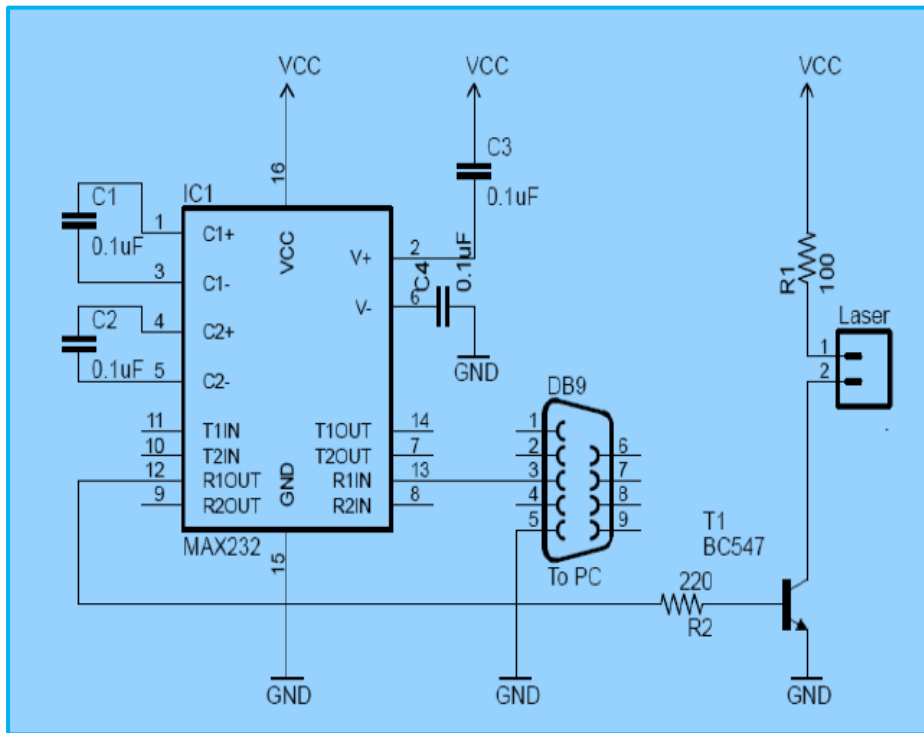

Figure 5. Transmitter circuit

3.3 Receiver

Silicon Photodiode is used at the receiver section. In order to process the data by the computer, MAX 232 IC is used to convert the TTL logic into RS 232 logic. The Max 232 IC is the key component of this circuit. The data is sent to the Max 232 IC through the DB9 pin. RS 232 logic input is converted to TTL logic output by the MAX 232 IC. The information is sent in binary format. By using a switching circuit, the light emitting diode is turned on and off in response to the received input. When zero is received, MAX 232's output is 0V. When 1 is received, it is 5V. The photodiode is wired directly to the Max 232 IC, which converts it to RS 232 logic. The information is then sent directly to the computer. This data is simple to process. "The photodiode is connected directly to the Max 232 IC, which converts it to RS 232 logic". The information is then sent directly to the computer. This data is simple to process. Figure 6 show the circuit diagram of the receiver circuit.

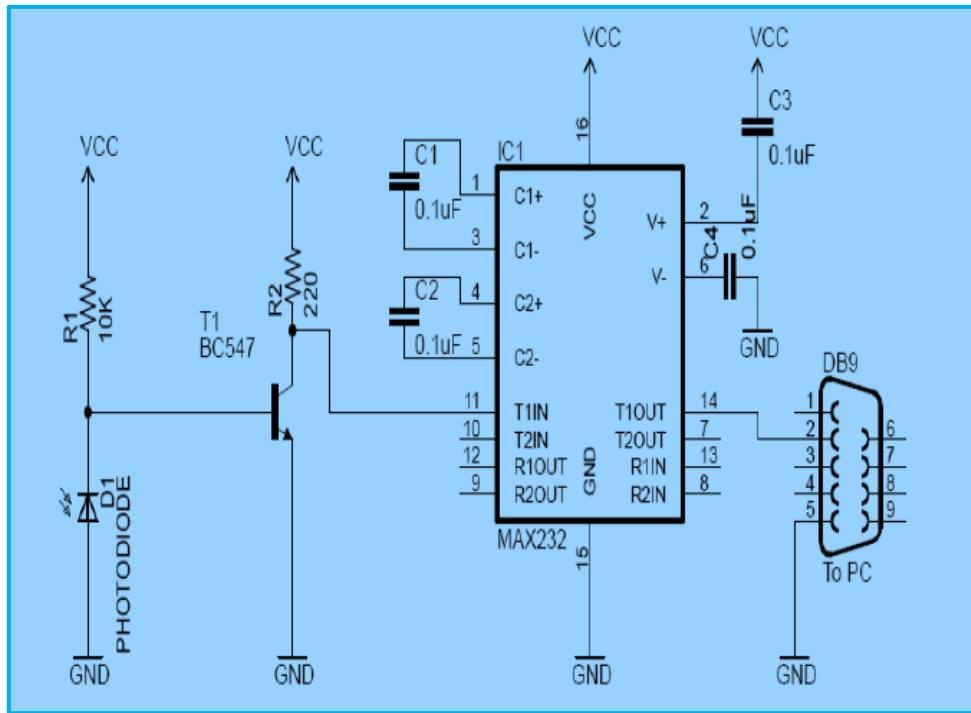

Figure 6. Receiver circuit

Figure 7. Shows the resultant received and transmitted signal.

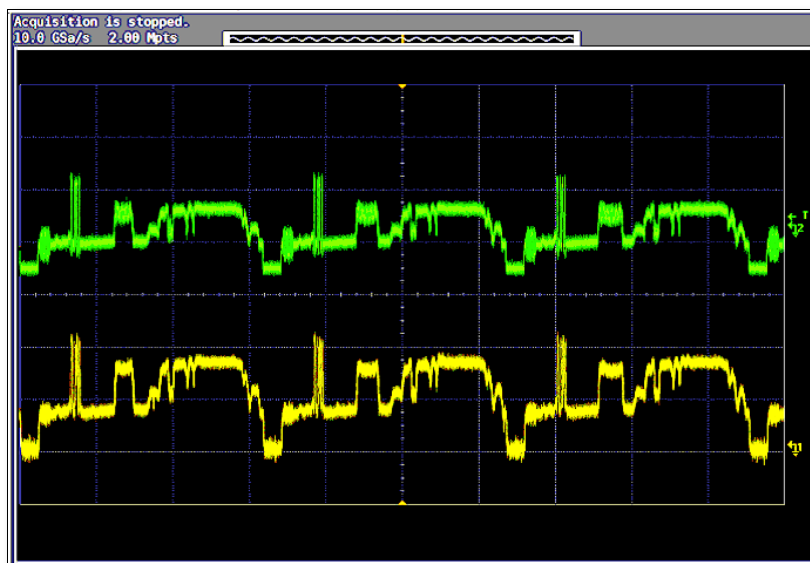

Figure 7. Transmitted and Received signal

In the proposed system, digital to analogue (DAC) is used at the transmitter side to convert the signal from digital to analogue which is further amplified through amplifier. The proposed system is mainly consist of four components namely transmitting computer, transmitting circuit, receiving circuit, and finally the receiving computer. The transmission start from the transmitting computer where the data is send to the Arduino on the transmitting circuit. The Arduino control the LED driver circuit which drives the LED's while modulating the inputs data using on off keys. The modulated data is then transmitted through visible light to the receiving

circuit. Photo diodes at the receiving side detects the modulating data which is further connected to the impedance amplifier. The impedance amplifier converts the optical signals from photo diodes to electrical signals. An analogue to digital converter (ADC) is used at the receiving Arduino circuit to get back the original data as the data at the time of transmission.

The signal transmission in the audio segment was done via the handset, which was positioned at the transmitter end. This secret digital signal is transformed to analogue. This transformed signal is now amplified and transmitted via the bread board in the form of a beam of LEDs. A power supply is included with the LED. The solar panel, which serves as a photo detector, was used to monitor variations in light intensity. This absorbs all LED fluctuations and sends the signal to a speaker that has been pre-amplified. Similarly, text to speech software is used instead of sending an analogue signal through smartphone. Software is used to provide text, and the software translates and reads the text. These audio signals produced while going through the text is transmitted through the variations caused in the LED array as mention above. Finally the audio signals is heard through a pre amplified speaker.

The system uses an Arduino Uno R3 as a Transmitter module for image transmission. The Light Emitting Diode (LED) is a light intermediary media for data transmission. On the Transmitter module's side, it acts as an image or image data sender. The LED light will be collected by the Receiver module using a photo detector, which will then be processed by Arduino Uno and displayed on the receiver's monitor screen.

4. Conclusion

This paper present video, audio, and image transmission through visible light communication. The device design is comprehensive, and the experimental findings are described and explained in detail. It has been demonstrated that high-quality video/audio and picture transmission can be accomplished over a distance of 12 feet, with improvements possible by adding a focusing lens between the transmitter and the receiver. Although limitation is still exist by comparing images before and after transmission. It is demonstrated that high-quality wireless optical transmission can be accomplished using LEDs. The measurement setup and results have also been presented. We obtain 100% successful result of transmitted image, audio, video, and text file. Experimental results show that high quality image, audio and video with the maximum distance of 12 feet's can be achieved through proper arrangement of transmitter and receiver. In a model space, the illumination distribution is simulated and compared for two light source arrangements. Future research will concentrate on real-time digital video/audio delivery and collaboration over a TCP/IP network. The VLC is still in its Initial developmental stage, but with the rapid advancements in technology being made step by step, it will soon be used in our everyday lives. Despite the research issues, we believe that the VLC system will become one of the most promising and popular wireless communication systems for future generations.

Acknowledgment

The authors are very thankful to the Department of Physics and Electrical Engineering, Northwest Normal University, Lanzhou, China. They provide us such an opportunity to write research paper in the field of Light Fidelity and visible light communication. I am also very thankful to my supervisor Mr. YU LONG BAI, Northwest Normal University China for his help and support throughout the paper.

References

1. Bhut J, Parmar D, Mehta K. LI-FI Technology—A Visible Light Communication. 2014 [cited 2021 May 27]; Available from: <http://citeseerx.ist.psu.edu/viewdoc/summary?doi=10.1.1.673.5033>
2. Singh AJ, Veeraiahgari A. Light Fidelity Technology. *IOSR J Electron Commun Eng.* 2014;9(2):115–8.
3. Karthika R, Balakrishnan S. Wireless Communication using Li-Fi Technology. 2015;2(3):32–40.
4. Mahato K. Light Fidelity (Li-Fi)/ Visible light communication—A potential solution to the global wireless spectrum shortage. *Int J Res Eng.* 2016;VI(January):2454–1915.
5. St AN. Li-Fi Technology : Data Transmission through Visible Light *International Journal of Advance Research in Li-Fi Technology : Data Transmission through Visible Light.* 2015;(JULY).
6. He Y, Ding L, Gong Y, Wang Y. Real-time Audio & Video Transmission System Based on Visible Light Communication. *Opt Photonics J.* 2013;03(02):153–7.
7. Ma’ruf MI, Othman MB, Sholeh HP. Audio transmission using visible light communication (VLC). *ARPN J Eng Appl Sci.* 2015;10(20):9835–8.
8. Singh S, Kakamanshadi G, Gupta S. Visible Light Communication—an emerging wireless communication technology. 2015 2nd Int Conf Recent Adv Eng Comput Sci RA ECS 2015. 2016;(December):21–3.
9. Madhuri G, Anjali K, Sakthi Prabha R. Transmission of data, audio and text signal using Li-fi technology. *IOP Conf Ser Mater Sci Eng.* 2020;872(1).
10. Tsaqifurrosyid A, Rosmiati M, Rizal MF. Image transmission using visible light communication in data communication. *Telkomnika (Telecommunication Comput Electron Control.* 2020;18(4):1771–6.
11. Sharma RR, Raunak, Sanganal A. Li-Fi Tech[1] R. R. Sharma, A. Sanganal, and others, “Li-Fi Technology: Transmission of data through light,” *Int. J. Comput. Technol. Appl.*, vol. 5, no. 1, p. 150, 2014. *nology: Transmission of data through light. Int J Comput Technol Appl.* 2014;5(1):150.
12. Ahfayd MH, Farhat ZA, Sibley MJN, Mather PJ, Lazaridis PI. Selection of high power LEDs for Li-Fi applications. 2018 25th Int Conf Telecommun ICT 2018. 2018;170–4.



Muhammad Imran

College of Physics and Electronics Engineering, Northwest Normal University, China



© 2021 by the authors. Author/authors are fully responsible for the text, figure, data in above pages. This article is an open access article distributed under the terms and conditions of the Creative Commons Attribution (CC BY) license (<http://creativecommons.org/licenses/by/4.0/>)

